

TOOLS FOR

Composites & Plastics

TOOLS FOR

Composites & Plastics

Composites & Plastics Tools

PCD-TIPPED Drills	PCD-Tipped Diamond Drills		58
PCD 203 Routers	2 Flute PCD-Tipped Routers Square End		59
CPCD 203 Routers	2 Flute PCD-Tipped Routers 118° Point		59
PCD-BN 201 Routers	2 Flute PCD-Tipped Routers Ball Nose		59
CR 402/602	4 and 6 Flute Compression Routers		60
CE 602/802	6 and 8 Flute Carbide Composite Routers		61
P810 Drills	Diamond Coated Drills		62
PM / PMD Routers	1 Flute Routers Uncoated		63
GTS 201 Routers	2 Flute Routers Uncoated		63
MINIATURES	(See Miniatures Applications)		77
A1 / MA1 201	(See Aluminum Applications)		12
SAWS	(See Saws Applications)		109
SPECIALS			

Call for Quote!
1-800-527-8833

PCD PCD-Tipped Diamond Drills

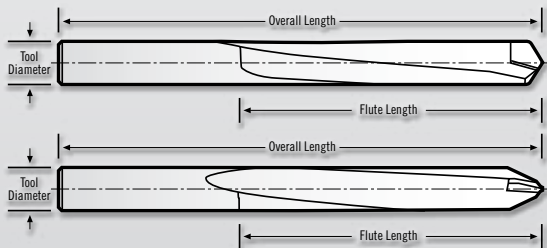
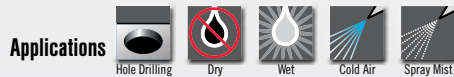

PCD-Tipped Drills Tolerances

Tool Dia. = $+0.000/-0.0005$ "
 Shank Dia. = $-0.001/-0.0002$ "
 LOC = $+0.030$ "
 OAL = $+0.060$ "

See Robblack Videos on
YouTube
www.youtube.com/user/RobblackCorp



NEW!



PCD 118° PCD-Tipped Standard Length – 4 Facet

Tool Diameter	Flute Length	Overall Length	Tool Number
.1655"	1.4"	2.7"	PCD-118-166
.1915"	1.4"	2.7"	PCD-118-192
.2210"	1.4"	2.7"	PCD-118-221
.2510"	1.4"	2.7"	PCD-118-251
.3125"	1.5"	2.7"	PCD-118-313
.3765"	1.5"	2.7"	PCD-118-377



PCD 135/20° PCD-Tipped Standard Length – 8 Facet

Tool Diameter	Flute Length	Overall Length	Tool Number
.1655"	1.4"	2.7"	PCD-13520-166
.1915"	1.4"	2.7"	PCD-13520-192
.2210"	1.4"	2.7"	PCD-13520-221
.2510"	1.4"	2.7"	PCD-13520-251
.3125"	1.5"	2.7"	PCD-13520-313
.3765"	1.5"	2.7"	PCD-13520-377



PCD 118/20° PCD-Tipped Standard Length – 8 Facet

Tool Diameter	Flute Length	Overall Length	Tool Number
.1655"	1.4"	2.7"	PCD-11820-166
.1915"	1.4"	2.7"	PCD-11820-192
.2210"	1.4"	2.7"	PCD-11820-221
.2510"	1.4"	2.7"	PCD-11820-251
.3125"	1.5"	2.7"	PCD-11820-313
.3765"	1.5"	2.7"	PCD-11820-377



PCD Elliptical PCD-Tipped Standard Length

Tool Diameter	Flute Length	Overall Length	Tool Number
.1655"	1.4"	2.7"	PCD-360-166
.1915"	1.4"	2.7"	PCD-360-192
.2210"	1.4"	2.7"	PCD-360-221
.2510"	1.4"	2.7"	PCD-360-251
.3125"	1.5"	2.7"	PCD-360-313
.3765"	1.5"	2.7"	PCD-360-377

PCD-Tipped Router Bits **PCD/CPCD**

Characteristics

- Square End
- Ball End
- 2 Flute
- 118° Drill Tip
- PCD Diamond

Applications

- Slotting
- Side Milling
- Helical Interpolation
- Ramping
- Roughing
- Semi-Finishing
- Finishing
- Dry
- Wet
- Cold Air
- Spray Mist

Materials

- Aluminum
- Copper
- Magnesium
- Plastics
- Composites
- Brass

10-20X
Tool Life
Over
Carbide!

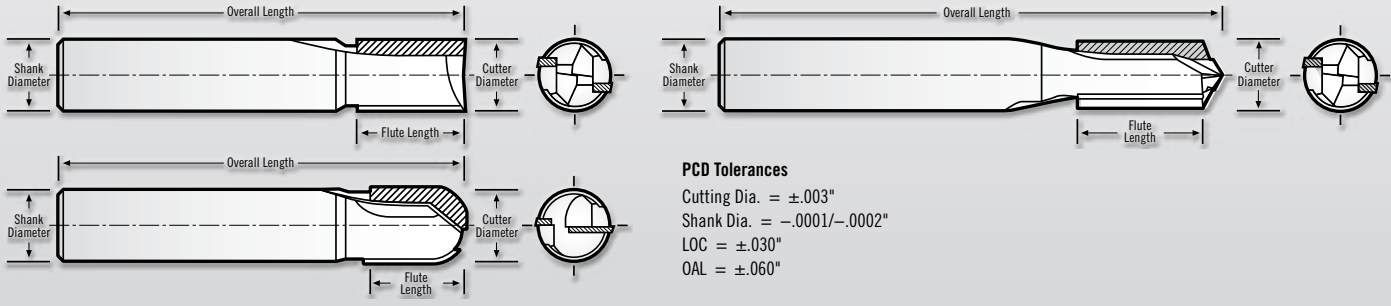

Composites & Plastics



CPCD-203 Composite 2 Flute Standard Length

Cutting Diameter	Shank Diameter	Flute Length	Drill Point	Overall Length	Tool Number
1/8"	1/8"	5/16"	118°	1-1/2"	CPCD-203-04
3/16"	3/16"	7/16"	118°	2"	CPCD-203-06
1/4"	1/4"	9/16"	118°	2"	CPCD-203-08
3/8"	3/8"	5/8"	118°	2-1/2"	CPCD-203-12
1/2"	1/2"	7/8"	118°	3"	CPCD-203-16
5/8"	5/8"	7/8"	118°	3-1/2"	CPCD-203-20
3/4"	3/4"	7/8"	118°	4"	CPCD-203-24

CPCD-203
Specifically Designed for
CFRP
Materials

See Robblack Videos on
YouTube
www.youtube.com/user/RobblackCorp



PCD-203 2 Flute Standard Length

Cutting Diameter	Shank Diameter	Flute Length	Overall Length	Tool Number
1/8"	1/8"	3/8"	1-1/2"	PCD-203-04
3/16"	3/16"	1/2"	2"	PCD-203-06
1/4"	1/4"	5/8"	2"	PCD-203-08
3/8"	3/8"	3/4"	2-1/2"	PCD-203-12
1/2"	1/2"	1"	3"	PCD-203-16
5/8"	5/8"	1"	3-1/2"	PCD-203-20
3/4"	3/4"	1"	4"	PCD-203-24



PCD-201BN 2 Flute Ball End Stub Length

Cutting Diameter	Shank Diameter	Flute Length	Overall Length	Tool Number
1/8"	1/8"	1/4"	1-1/2"	PCD-201-04BN
3/16"	3/16"	5/16"	2"	PCD-201-06BN
1/4"	1/4"	3/8"	2"	PCD-201-08BN
3/8"	3/8"	1/2"	2-1/2"	PCD-201-12BN
1/2"	1/2"	5/8"	3"	PCD-201-16BN
5/8"	5/8"	7/8"	3-1/2"	PCD-201-20BN
3/4"	3/4"	1"	4"	PCD-201-24BN

CR Compression Router

Characteristics

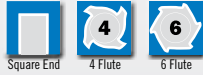

Applications



Materials



Coatings

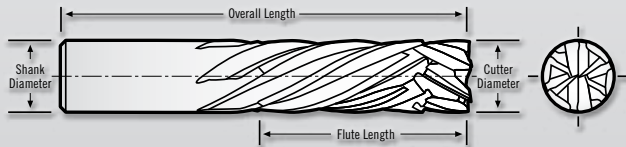

CR Tolerances

Cutting Dia. = $-.001/-0.003$ "
 Shank Dia. = $-.0001/-0.0002$ "
 LOC ($<5/16$ ") = $+0.020/+0.030$ "
 ($>5/16$ ") = $+0.030/+0.060$ "
 OAL = ± 0.060 "



CR Compression Router – 4/6 Flute Uncoated

Cutting Diameter	Shank Diameter	Number of Flutes	Upshear Length	Flute Length	Overall Length	Tool Number Uncoated
1/4"	1/4"	4	3/16"	3/4"	2-1/2"	CR-402-08
3/8"	3/8"	6	1/4"	1"	2-1/2"	CR-602-12
1/2"	1/2"	6	1/4"	1-1/8"	3"	CR-602-16



CR Compression Router – 4/6 Flute Black Widow DLC Coated

Cutting Diameter	Shank Diameter	Number of Flutes	Upshear Length	Flute Length	Overall Length	Tool Number DLC Coated
1/4"	1/4"	4	3/16"	3/4"	2-1/2"	CR-402-08 DLC
3/8"	3/8"	6	1/4"	1"	2-1/2"	CR-602-12 DLC
1/2"	1/2"	6	1/4"	1-1/8"	3"	CR-602-16 DLC



CR Compression Router – 4/6 Flute Diamond Coated

Cutting Diameter	Shank Diameter	Number of Flutes	Upshear Length	Flute Length	Overall Length	Tool Number Diamond Coated
1/4"	1/4"	4	3/16"	3/4"	2-1/2"	CR-402-08 D
3/8"	3/8"	6	1/4"	1"	2-1/2"	CR-602-12 D
1/2"	1/2"	6	1/4"	1-1/8"	3"	CR-602-16 D

Carbide Composite Router **CE**

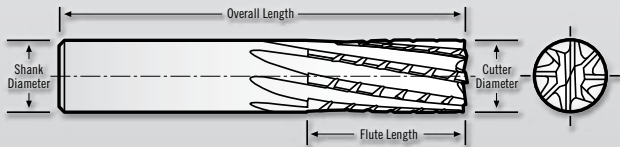

CE Tolerances

Cutting Dia. = $-.001/-0.003$ "
 Shank Dia. = $-.0001/-0.0002$ "
 LOC ($<5/16$ ") = $+.020/+0.030$ "
 ($>5/16$ ") = $+.030/+0.060$ "
 OAL = ± 0.060 "



Composites & Plastics



CE Carbide Composite Router – 6/8 Flute Uncoated

Cutting Diameter	Shank Diameter	Number of Flutes	Flute Length	Overall Length	Tool Number Uncoated
1/4"	1/4"	6	3/4"	2-1/2"	CE-602-08
3/8"	3/8"	8	1"	2-1/2"	CE-802-12
1/2"	1/2"	8	1-1/8"	3"	CE-802-16



CE Carbide Composite Router – 6/8 Flute Black Widow DLC Coated

Cutting Diameter	Shank Diameter	Number of Flutes	Flute Length	Overall Length	Tool Number DLC Coated
1/4"	1/4"	6	3/4"	2-1/2"	CE-602-08 DLC
3/8"	3/8"	8	1"	2-1/2"	CE-802-12 DLC
1/2"	1/2"	8	1-1/8"	3"	CE-802-16 DLC



CE Carbide Composite Router – 6/8 Flute Diamond Coated

Cutting Diameter	Shank Diameter	Number of Flutes	Flute Length	Overall Length	Tool Number Diamond Coated
1/4"	1/4"	6	3/4"	2-1/2"	CE-602-08 D
3/8"	3/8"	8	1"	2-1/2"	CE-802-12 D
1/2"	1/2"	8	1-1/8"	3"	CE-802-16 D

P810/F104 Diamond Coated Aircraft Drills

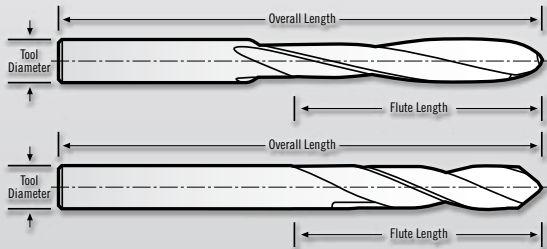
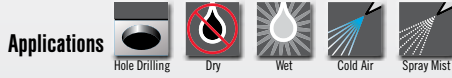
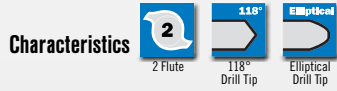

P810/F104 Drills Tolerances
 Tool Dia. = $+0.0000/-0.0005$ "
 Shank Dia. = $-0.0001/-0.0002$ "
 LOC = $+0.030$ "
 OAL = $+0.060$ "



P810 118° Diamond Coated Standard Length Drills - 4 Facet

Tool Diameter	Flute Length	Overall Length	Tool Number Diamond Coated
0.0980"	1.4"	2.7"	P810-100345-1
0.1285"	1.4"	2.7"	P810-100344-1
0.1421"	1.4"	2.7"	P810-100402-1
0.1560"	1.4"	2.7"	P810-100409-1
0.1655"	1.4"	2.7"	P810-100335-1
0.1734"	1.4"	2.7"	P810-100404-1
0.1900"	1.4"	2.7"	P810-100400-1
0.1915"	1.4"	2.7"	P810-100336-1
0.1990"	1.4"	2.7"	P810-100411-1
0.2055"	1.4"	2.7"	P810-100405-1
0.2210"	1.4"	2.7"	P810-100346-1
0.2515"	1.4"	2.7"	P810-100337-1
0.2590"	1.4"	2.7"	P810-100406-1
0.2710"	1.4"	2.7"	P810-100407-1
0.2770"	1.4"	2.7"	P810-100412-1
0.2800"	1.4"	2.7"	P810-100408-1
0.2812"	1.4"	2.7"	P810-100410-1
0.3135"	1.5"	2.7"	P810-100338-1
0.3765"	1.5"	2.7"	P810-100341-1



F104 Elliptical Diamond Coated Standard Length Drills

Tool Diameter	Flute Length	Overall Length	Tool Number Diamond Coated
0.0980"	1.4"	2.7"	F104-100001-1
0.1285"	1.4"	2.7"	F104-100003-1
0.1421"	1.4"	2.7"	F104-100005-1
0.1560"	1.4"	2.7"	F104-100006-1
0.1655"	1.4"	2.7"	F104-100007-1
0.1734"	1.4"	2.7"	F104-100008-1
0.1900"	1.4"	2.7"	F104-100009-1
0.1915"	1.4"	2.7"	F104-100010-1
0.1990"	1.4"	2.7"	F104-100011-1
0.2055"	1.4"	2.7"	F104-100012-1
0.2210"	1.4"	2.7"	F104-100004-1
0.2515"	1.4"	2.7"	F104-100002-1
0.2590"	1.4"	2.7"	F104-100013-1
0.2710"	1.4"	2.7"	F104-100014-1
0.2770"	1.4"	2.7"	F104-100015-1
0.2800"	1.4"	2.7"	F104-100016-1
0.2812"	1.4"	2.7"	F104-100017-1
0.3135"	1.5"	2.7"	F104-100018-1
0.3765"	1.5"	2.7"	F104-100019-1

Tuffy Grade Carbide Router Bits **PM/GTS**

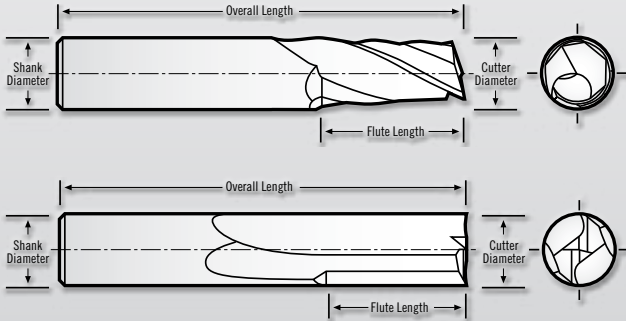

PM Series Tolerances
 Cutting Dia. = $+0.000/-0.002$ "
 Shank Dia. = $-0.0001/-0.0002$ "
 LOC = $+0.060/-0.000$ "
 OAL = ± 0.060 "

GTS Series Tolerances
 Cutting Dia. = $+0.000/-0.002$ "
 Shank Dia. = $-0.0001/-0.0002$ "
 LOC = $+0.060/-0.000$ "
 OAL = ± 0.060 "



PM Up Shear 1 Flute Tuffy Grade

Cutting Diameter	Shank Diameter	Flute Length	Overall Length	Tool Number
1/8"	1/8"	1/2"	2"	PM-104-04
1/8"	1/4"	1/2"	2"	PM-108-04
3/16"	3/16"	5/8"	2"	PM-106-06
3/16"	1/4"	5/8"	2"	PM-108-06
3/16"	1/4"	1-1/4"	3"	PM-108-06L
1/4"	1/4"	3/4"	2"	PM-108-08
1/4"	1/4"	1-1/2"	3"	PM-108-08L
3/8"	3/8"	1-1/4"	3"	PM-112-12
1/2"	1/2"	1-1/2"	4"	PM-116-16



PMD Down Shear 1 Flute Tuffy Grade

Cutting Diameter	Shank Diameter	Flute Length	Overall Length	Tool Number
1/8"	1/4"	1/2"	2"	PMD-108-04
3/16"	1/4"	5/8"	2"	PMD-108-06
1/4"	1/4"	3/4"	2"	PMD-108-08



GTS 2 Flute Tuffy Grade Straight Flute

Cutting Diameter	Shank Diameter	Flute Length	Overall Length	Tool Number
1/8"	1/4"	1/2"	2"	GTS-201-04
1/4"	1/4"	3/4"	2-1/2"	GTS-201-08
3/8"	3/8"	7/8"	2-1/2"	GTS-201-12
1/2"	1/2"	1"	3"	GTS-201-16

Composites & Plastics Tools in Other Sections

MINIATURES

(See Miniatures Applications)



77

A1 / MA1 201

(See Aluminum Applications)



12

SAWS

(See Saws Applications)



109

SPECIALS

